

LTC 9215/00, LTC 9215/00S, LTC 9219/01

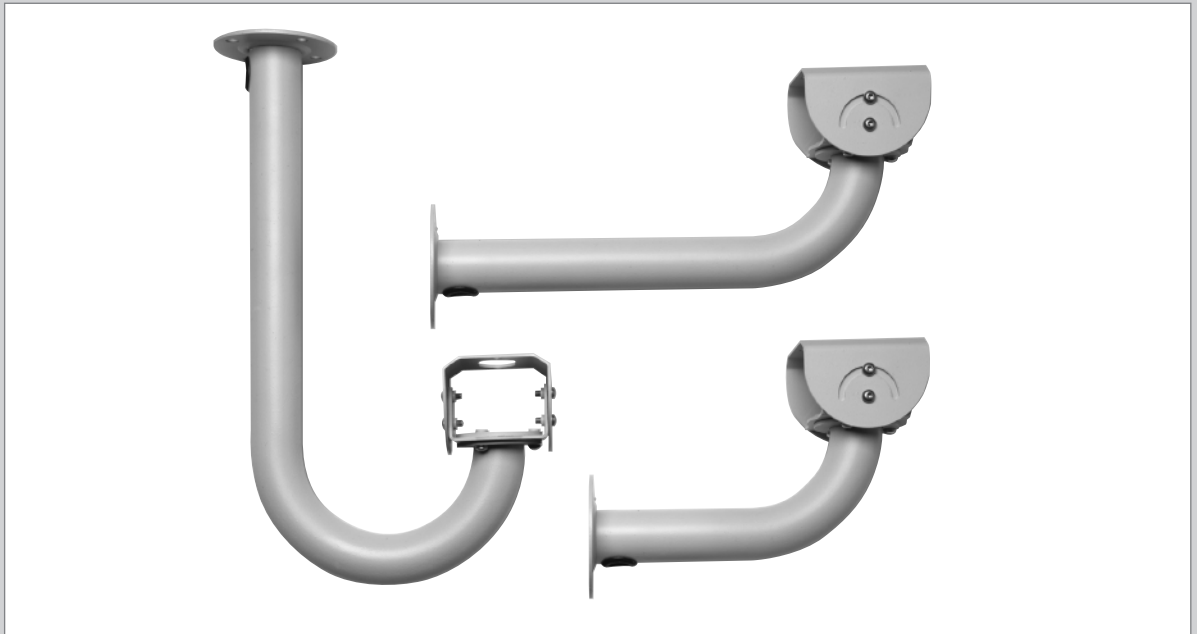

Security Systems

EN | Instruction Booklet
Indoor/Outdoor
Feed-through Mounts

BOSCH

SAFETY PRECAUTIONS



The exclamation point within an equilateral triangle is intended to alert the user to presence of important operating and maintenance (servicing) instructions in the literature accompanying the appliance.

SECURITE



Le point d'exclamation à l'intérieur d'un triangle équilatéral avertit l'utilisateur de la présence d'instructions importantes d'utilisation et de maintenance dans la documentation accompagnant l'appareil.

SICHERHEITSVORKENHRUNGEN



Das Ausrufezeichen in dem gleichseitigen Dreieck ist dazu da, den Benutzer auf wichtige Inbetriebnahme- und Instandhaltungs-vorschriften hinzuweisen, die dem Gerät in Form einer Broschüre beigelegt sind.

PRECAUCIONES DE SEGURIDAD



El símbolo de exclamación dentro de un triángulo equilátero, se muestra con el objetivo de alertar al usuario de que instrucciones de operación y mantenimiento importantes acompañan al equipo.

I UNPACKING

This equipment should be unpacked carefully and handled with care.

Check for the following items:

- Model number of unit.
- Instructions for Use.

If an item appears to have been damaged in shipment, replace it properly in its carton and notify the shipper. If any items are missing, notify Bosch Security Systems.

The shipping carton is the safest container in which the unit may be transported. Save it for possible future use.

2 SERVICE

If the unit ever needs repair service, the customer should contact the nearest Bosch Security Systems, Inc. Service Center for authorization to return and shipping instructions.

Service Centers

U.S.A.: 800-366-2283 or 717-735-6638

Fax: 800-366-1329 or 717-735-6639

Email: BoschCCTVParts@ca.slr.com

Canada: 514-738-2434

Europe, Middle East & Asia Pacific Regions

32-1-440-0711

For additional information, see www.boschsecurity.com

3 DESCRIPTION

LTC 9215/00 30-cm (12-in), LTC 9215/00S 18-cm (7-in), and LTC 9219/01 40-cm (15-in) Feed-through Mounts.

This indoor/outdoor mounting equipment is designed for fixed camera or camera housing installations up to 9 kg (20 lb) rated load. These models are made of lightweight aluminum and feature welded construction, providing an extremely rigid camera mount. The LTC 9215/00S has been designed specifically for the LTC 9480 series housings, while the LTC 9215/00 and LTC 9219/01 can be used with the LTC 9480, LTC 9483, and LTC 9488 series camera housings. All mounts come fully assembled.

4 INSTALLATION

1. Determine a secure wall mounting location.



WARNING: All mounts are designed to support a load only in a vertical direction. Mounts MUST be positioned as shown under SPECIFICATIONS.



Warning:

- a. For a secure installation, use four 8-mm (5/16-in) diameter fasteners (not included). Use stainless steel or zinc plated fasteners.
 - b. If bolts are used, they should extend through the mounting surface and be secured with flat washers, lock washers, and nuts on the opposite side. Each bolt must have a minimum pull-out strength of 200 kg (450 lb).
 - c. If studs are used, they should be anchored in concrete or welded to a steel backer plate. Each stud must have a minimum pull out strength of 200 kg (450 lb).
 - d. If the wall mount is attached to wood or to a blind structure (with no access to the rear), each fastener must have a minimum pull-out strength of at least 200 kg (450 lb).
2. Locate the four holes or stud locations using the flange as a template (four holes equally spaced on a 69.9-mm (2-3/4-in) bolt circle).
 3. Feed wires through the large hole in the flange or through the slot on the surface where the camera housing mounts.
 4. Install the mount using bolts or studs at least 8-mm (5/16-in) in diameter.
 5. To mount the camera housing:
 - a. Mount housings with two 1/4-20 bolts and lock washers (not included).
 - b. Lock mount head in position by using the supplied 1/8-inch long-arm hex wrench to tighten screws.

5 SPECIFICATIONS

5.1 LTC 9215/00 30-cm (12-in) Indoor/Outdoor Feed-through Mount

Maximum Load: 9 kg (20 lb).

Mounting Head: Adjustable. 360° pan, 180° tilt.

Finish: Light gray.

Approx. Weight: 0.4 kg (0.9 lb).

Accessory for LTC 9215/00: LTC 9213/00 Pole Mount Adapter.

WARNING: All mounts must be mounted as shown.

5.2 LTC 9215/00S 18-cm (7-in) Indoor/Outdoor Feed-through Mount

Maximum Load: 9 kg (20 lb).

Mounting Head: Adjustable. 360° pan, 180° tilt.

Finish: Light gray.

Approx. Weight: 0.3 kg (0.7 lb).

Accessory for LTC 9215/00S: LTC 9213/00 Pole Mount Adapter.

WARNING: All mounts must be mounted as shown.

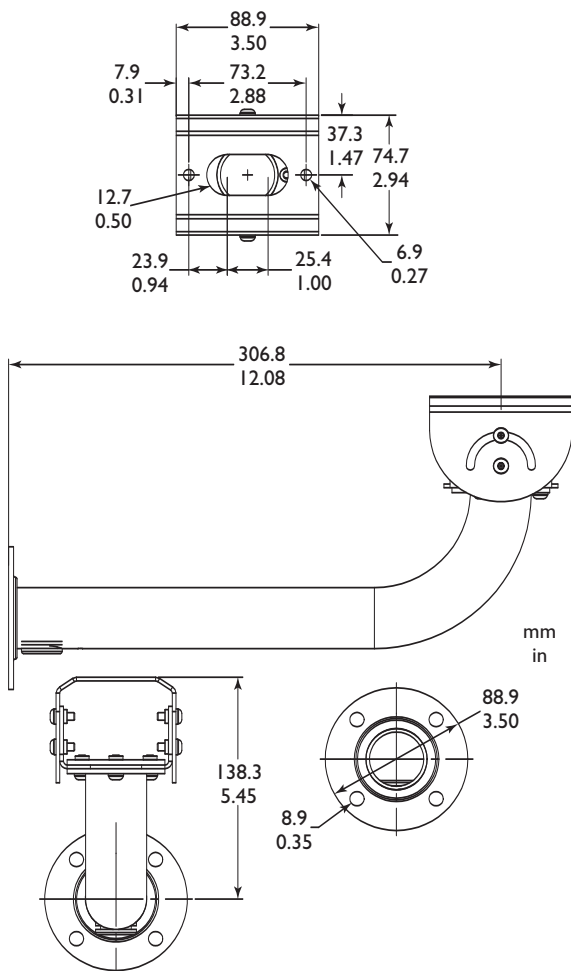

LTC 9215/00 Feed-through Mount

5.3 LTC 9219/01 40-cm (15-in) Indoor/Outdoor Feed-through J-mount

Maximum Load: 9 kg (20 lb).

Mounting Head: Adjustable. 360° pan, 180° tilt.

Finish: Light gray.

Approx. Weight: 0.55 kg (1.2 lb).

WARNING: All mounts must be mounted as shown.

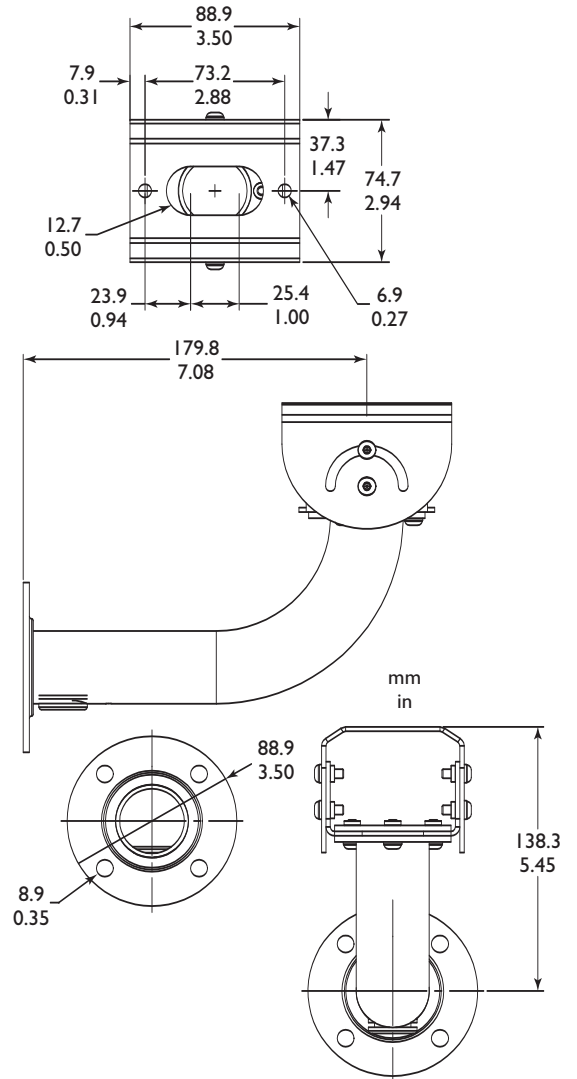

LTC 9215/00S Feed-through Mount

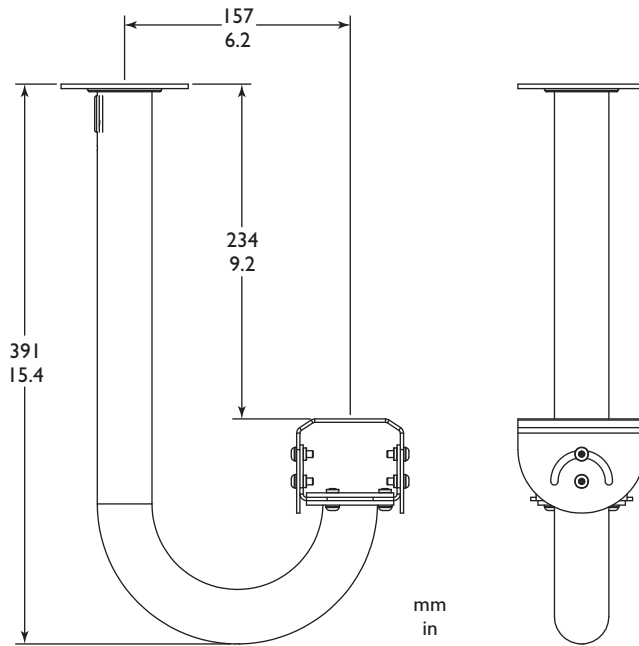

LTC 9219/01 Feed-through J-mount

Americas

Bosch Security Systems
 130 Perinton Parkway
 Fairport, New York, 14450, USA
 Phone: +1 (585) 223 4060
 +1 (800) 289 0096
 security.sales@us.bosch.com
 http://www.boschsecurity.us

Europe, Middle East, Africa

Bosch Security Systems B.V.
 P.O. Box 80002
 5600 JB Eindhoven, The Netherlands
 Phone: +31 (0) 40 27 83955
 Fax: +31 (0) 40 27 86668
 emea.securitysystems@bosch.com
 http://www.boschsecurity.com

Asia-Pacific

Bosch Security Systems Pte Ltd
 38C Jalan Pemimpin
 Singapore 577180
 Phone: +65 6319 3450
 Fax: +65 6319 3499
 apr.securitysystems@bosch.com
 http://www.boschsecurity.com

@ 2005 Bosch Security Systems GmbH

100 0080 001 BOS | Updated July 18, 2005 | Data subject to change without notice.

BOSCH