

1 | Overview

The B920 keypad is an SDI2 bus compatible device. Each keypad has an LCD display that shows two-line system messages and user adjustable options such as volume and display brightness.

The keypad connects to the SDI2 bus on the control panel using terminal wiring. You can connect more than one keypad to the control panel by wiring them in parallel.

You can program, diagnose, and troubleshoot the system from the control panel keypad, as well as remotely through Remote Programming Software (RPS).

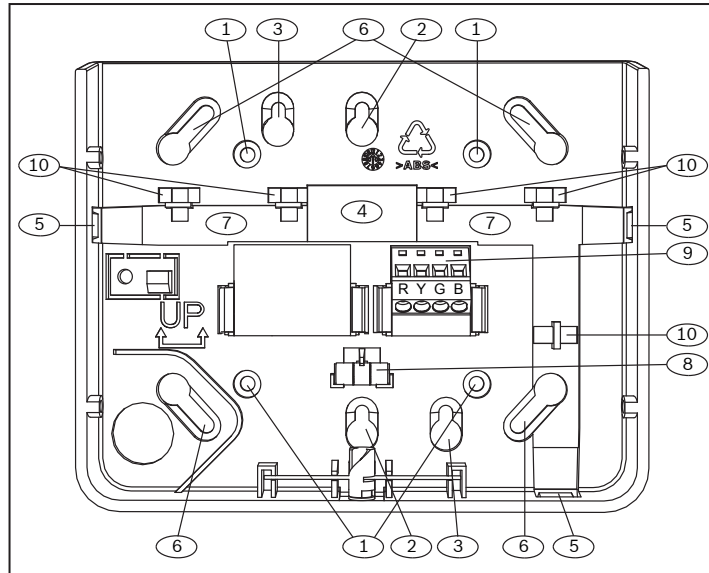

Figure 1.1: Keypad base overview

Callout – Description

1 – Wall mount holes
2 – Single gang box holes
3 – Double gang box holes
4 – Wire opening
5 – Surface mount wire openings
6 – Gang box holes (3-4 in)
7 – Surface mount wire channel
8 – Bubble level
9 – SDI2 wiring terminal block
10 – Wire tie posts

2 | SDI2 address switches

Two switches determine the address for the keypad. The control panel uses the address for communications. To set the switches, use a slotted screwdriver.

2.1 | Accessing the address switches

1. Unlock the keypad by turning the lock counter-clockwise. Refer to *Figure 2.1*.
2. Hold the keypad by the base in one hand. With the other hand, gently push down on the keypad to remove it from the base. Refer to *Figure 2.2*.
3. Look at the back of the keypad, and locate the switches. Refer to *Figure 2.3*.

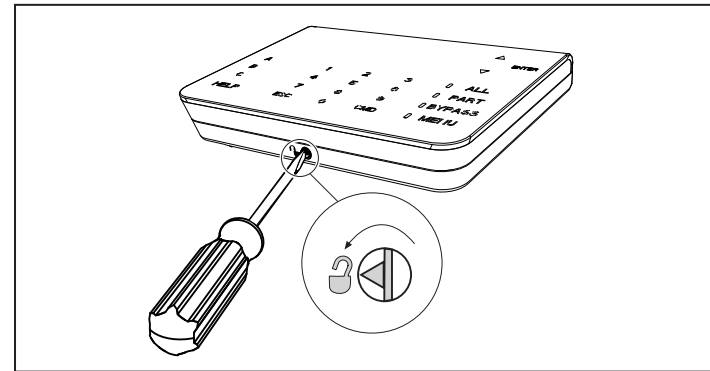

Figure 2.1: Unlocking the keypad

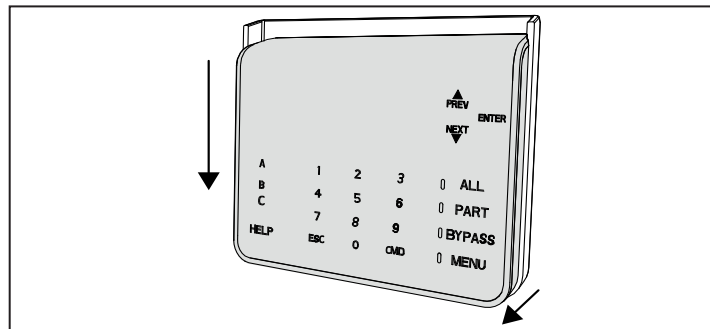

Figure 2.2: Removing the keypad from base

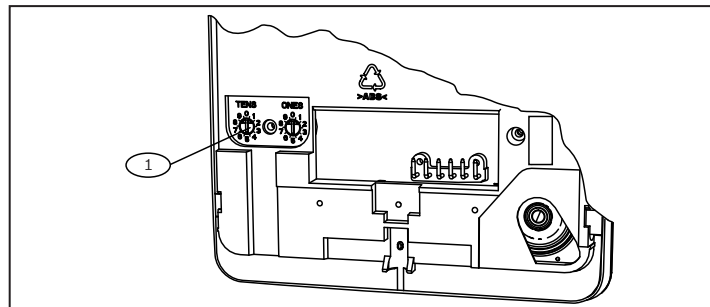

Figure 2.3: Switches location

Callout – Description

1 – Address switches

2.2 | Set the address switches

Set the address switches per the control panel configuration. If multiple SDI2 keypads reside on the same system, each SDI2 keypad must have a unique address. For single-digit addresses 1 through 9, set the tens switch to 0. *Figure 2.4* shows the address switch setting for address 1.

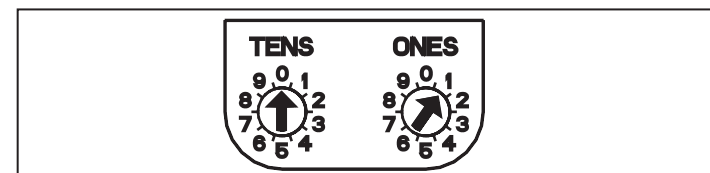

Figure 2.4: Address switches

3 | Installing

After you set the address switches for the proper address, mount the keypad base, wire to the control panel, and attach the keypad to the base.



Caution!

Remove all power (AC and battery) before making any connections. Failure to do so might result in personal injury and/or equipment damage.

3.1 | Mounting the keypad

You can surface mount the keypad, or mount it to standard electrical boxes, including single gang boxes.

Mounting the keypad:

1. To mark the desired mounting surface, use the base as a template. Refer to *Figure 1.1* for mounting hole and wiring locations.
2. Pull the wiring through the desired wire opening in the base.
3. To mount the base to the desired mounting surface, use the appropriate mounting hardware (included). Refer to *Figure 1.1* for mounting hole and wiring locations.

3.2 | Wiring to the control panel

When you wire the keypad to a control panel, use the control panel terminals labeled R, Y, G, B (PWR, A, B, COM). Connect them to the keypad terminals labeled R, Y, G, B. Refer to *Figure 3.1*.

You can connect keypads to the SDI2 data bus by parallel wire run from the control panel to each keypad, wire from keypad to keypad, or a combination of the two techniques. Refer to *Figure 3.2*.

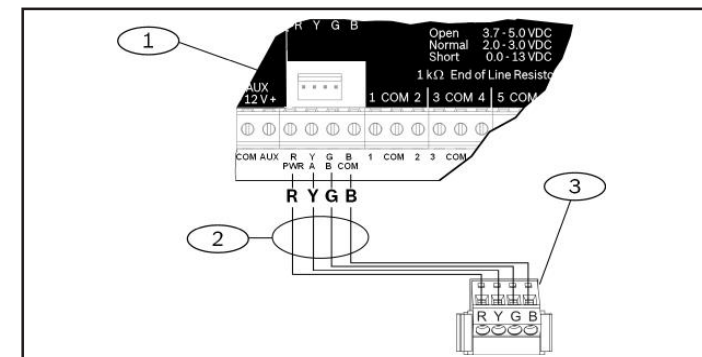

Figure 3.1: Wiring the keypad to the SDI2 bus connection (B5512 shown)

Callout – Description

1 – Control panel
2 – Terminal wiring
3 – Keypad's wiring terminal block

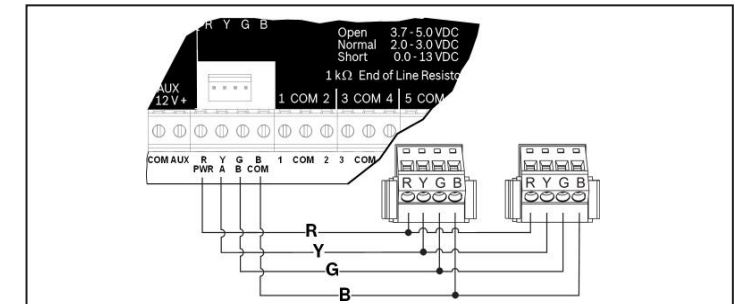

Figure 3.2: Installing multiple keypads using the SDI2 terminals

Reconnect the keypad to the base by sliding the keypad onto the base (reverse of *Step 2*). The keypad automatically locks onto the base. Apply power to the system.

4 | Display

You can adjust the keypad's display brightness level, and you can turn the keypad's nightlight feature on or off.

Adjusting the keypad display brightness:

1. Press [MENU] to open the Main menu.
2. Use [NEXT] to go to the Press 5 for Settings Menu option, or press [5].
3. Use [NEXT] to go to the Press 4 for Keypad Config option, or press [4].
4. Press [1] to adjust the brightness.
5. Use [PREV] or [NEXT] to adjust the brightness level. The changes apply immediately.
6. Press [ESC] to exit the menu.

Turning the keypad nightlight on or off (control panel version 2.1 or higher):

1. Press [MENU] to open the Main menu.
2. Use [NEXT] to go to the Press 5 for Settings Menu option, or press [5].
3. Use [NEXT] to go to the Press 4 for Keypad Config option, or press [4].
4. Use [NEXT] to go to the Press 4 for Nightlight option, or press [4].
5. Use [PREV] or [NEXT] to toggle between the Yes and No options.
6. Press [ENTER] while viewing the desired option to save the programming.
7. Press [ESC] to exit the menu.

5 | Status indicators

You can diagnose and troubleshoot the system using the keypad's status indicators. Refer to *Table 5.1*.





Status indicator	Function LED On
	Ready to turn on (arm)
	Turned on (armed)
	System trouble
GAS	Gas alarm
	AC power present

Table 5.1: Keypad status indicators

6 | Audible tones

The keypad has a built-in speaker that produces several distinct warning tones. The keypad backlight illuminates when it emits an audible tone.

Tone	Description
Fire alarm	When an area is in fire alarm, the keypad emits a pulsed, high-pitched bell tone.
Gas alarm	When a gas point activates, the keypad emits a unique high-pitched tone.
User alarm	When a user alarm (such as panic and medical alarms) occurs, the tone sounds for the programmed amount of time.
Burglary alarm	When an area is in alarm, the keypad emits a steady, high-pitched bell tone.
Entry delay	During delay periods, the keypad emits an intermittent beep to remind the user to disarm the area.
Exit delay	During exit delay, the keypad emits an intermittent beep.
Invalid button buzz	When an invalid button, or sequence of buttons, is pressed, the keypad emits a flat buzz tone.
Keypress	When the keypad accepts an entry, it emits a muted beep tone as each button is pressed.
Trouble	When a trouble event occurs, such as a service alert, the keypad emits a two-tone warble until you enter a programmed passcode with the appropriate authority.
Watch point fault	Anytime a watch point is faulted, a single clean tweedle tone alerts the user.

Table 6.1: Keypad audible tones

7 | Supervision

The control panel supervises all keypads on the SDI2 bus. If a supervised keypad fails to respond to the control panel, the control panel declares a Missing Keypad Trouble. When the control panel can again communicate with the keypad, it restores the Missing Keypad Trouble.

During a Missing Keypad Trouble, any connected keypad that maintained contact with the control panel shows the Missing Keypad Trouble as its idle text and shows the missing keypad's address. The communicating keypads also sound a trouble tone. Users can silence the trouble tone. If no other troubles exist, the tone silences when the missing keypad restores.

8 | Showing the firmware version

Showing the keypad firmware version:

- To remove power to the keypad, remove the keypad from the base. Refer to *Figures 2.1* and *2.2*.
- To restore power to the keypad, return the keypad to the base.

The keypad shows the model number, keypad address, and firmware version for 10 seconds.



NOTICE!

You can also view a keypad's firmware version in RPS.

9 | Keypad cleaning

To clean your keypad, use a soft cloth and a non-abrasive cleaning solution (for example, microfiber cloth and eyeglass cleaner). Spray the cleaner onto the cloth. Do not spray cleaners directly onto the keypad.

10 | Certifications

Region	Certification
US	UL 365 - Police Station Connected Burglar Alarm Units and Systems
	UL 609 - Local Burglar Alarm Units and Systems
	UL 985 - Household Fire Warning System Units
	UL 1023 - Household Burglar-Alarm System Units
	UL 1076 - Proprietary Burglar Alarm Units and Systems
	UL 1610 - Central Station Burglar Alarm Units
	CSFM - California Office of The State Fire Marshal
CA	FCC Part 15 Class B
	Canada CAN/ULC S303 - Local Burglar Alarm Units and Systems
	CAN/ULC S304 - Signal Receiving Centre and Premise Alarm Control Units
	CAN/ULC S559 - Fire Signal Receiving Centres and Systems
	ULC-ORD C1023 - Household Burglar Alarm System Units
	ULC-ORD C1076 - Proprietary Burglar Alarm Units and Systems
ICES-003 - Digital Apparatus	

11 | Specifications

Dimensions	6.2 in x 4.7 in x 1 in (158 mm x 120 mm x 26 mm)
Voltage (input)	12 VDC nominal
Current	35 mA in standby mode 70 mA in alarm mode
Operating temperature	0°C to +50°C (+32°F to +122°F)
Relative humidity	5% to 93% at +32°C (+90°F) non-condensing
Terminal wire size	12 AWG to 22 AWG (2 mm to 65 mm)
SDI2 wiring	Maximum distance - wire size (unshielded wire only): 1000 ft (305 m) - 22 AWG (0.65 mm)
Compatibility	B9512G/B9512G-E B8512G/B8512G-E B6512 B5512 B4512 B3512 D9412GV4 version 2.0 and higher D7412GV4 version 2.0 and higher (Refer to the control panel installation document for number of supported devices.)

Copyright

This document is the intellectual property of Bosch Security Systems, Inc. and is protected by copyright. All rights reserved.

Trademarks

All hardware and software product names used in this document are likely to be registered trademarks and must be treated accordingly.

Bosch Security Systems, Inc. product manufacturing dates

Use the serial number located on the product label and refer to the Bosch Security Systems, Inc. website at <http://www.boschsecurity.com/datecodes/>.



Two-line Alphanumeric Keypad B920



en Installation Guide

Bosch Security Systems, Inc.
130 Perinton Parkway
Fairport, NY 14450
USA
www.boschsecurity.com

